

TABLE OF CONTENTS

INTRODUCTION.....	1
TABLE OF CONTENTS	2
GENERAL SAFETY WARNINGS.....	3
ASSEMBLY INSTRUCTIONS	4
Seam Phantom® Packages and Accessories	4
Tools Needed for Assembly	4
Assembling the Seam Phantom® - Electric Version.....	5
Assembling the Seam Phantom® - Air Version	9
Adjusting the Seam Phantom®	11
USE INSTRUCTIONS.....	12
Before Using the Seam Phantom®	12
How to Operate	13
Work Piece Setup	13
Guide Setup.....	13
Back Grind or “Undercut”	14
Dressing the Seam (Suggested Process)	14
After Use	16
CLEANING AND MAINTENANCE	17
CONTACT NSI SOLUTIONS.....	18

GENERAL SAFETY WARNINGS



Read and Understand All Instructions

Failure to follow all instructions listed below may result in electric shock, fire and/or serious personal injury.



Use Proper Safety Gear

Always wear eye protection and proper personal safety equipment when using this product.



Observe Maximum RPM

Maximum 4000 RPM for the turbo Abrasives and 10000 RPM for the 2" cup wheel.



Caution

Firmly attach all components before use.



Wet Use Only

All Turbo abrasives and cup wheels in this kit are designed for wet use only.



Caution

Observe all safety instructions provided with the electric grinder or air polisher and all associated tools and accessories.

ASSEMBLY INSTRUCTIONS

Seam Phantom® Packages and Accessories

Package SP-E: Seam Phantom® Electric Grinder Package Package SP-A: Seam Phantom® Air Polisher Package	Package SP-E (electric)	Package SP-A (air)
(1) Seam Phantom®	•	•
(1) Adapter for Air Tool		•
(1) Arbor Extension		•
(1) Arbor Spacer	•	
(1) Splash Guard Angle	•	
(4) Screws Required for Assembly	•	•
(4) Washers (to allow for angle adjustment of the grinding head)	•	•
(1) Spray Skirt	•	
(1) Makita 9565CV, 9564CV grinder or Makita GA5042C, GA4542C grinder (Units shipped after October 5, 2015). (See web page for international model numbers)	Supplied by Customer	
(1) Center Water Feed Air Polisher (Alpha Air-658 & Air 680, Barranca BD-2321, Flex PLW923S, WEHA QB9, Cyclone MVP, Gison GPW-7 (14mm) or equivalent)		Supplied by Customer
(1) 48" Glide Guide Rail	•	•
72" Glide Guide Rail	Optional	Optional
92" Glide Guide Rail	Optional	Optional
(1) Tool Box for Seam Phantom® and Attachments	•	
(1) GFCI	•	
(1) SL3-ADAPT - 5/8-11 Snail Lock Adapter (M14 Adapter is available)	•	•
(1) SL3-60 – 60 Grit Turbo Abrasive Pad	•	•
(1) SL3-150 - 150 grit Turbo Abrasive Pad	•	•
(1) SL3-300 – 300 Grit Turbo Abrasive Pad	•	•
(1) SL3-Cup 2 – 2" Cup Wheel for back grinding	•	•
(2) C-Clamps for clamping Glide Guide	•	•
(2) Gauge Blocks	•	•
(1) Assembly and Usage Instruction Manual	•	•

KEY

- These items supplied with the package as noted.

NOTE

Optional These items are optional – available for purchase separately

Tools Needed for Assembly

Electric Version

- 3 mm Allen (Hex) Wrench
- Denatured Alcohol (or equivalent) to prepare electric grinder body for spray skirt installation
- Crescent Wrench (1 1/8" capacity)

Air Version

- 3/4" Wrench
- 1/8 Allen (Hex) Wrench
- 3 mm Allen (Hex) Wrench
- Crescent Wrench (1 1/8" capacity)

Assembling the Seam Phantom® - Electric Version



Caution

Always be sure that the tool is switched off and unplugged before performing any work on the tool.

1. If installed, remove wheel guard (item 1) from grinder (See Figure 1). Guard will not be needed with the Seam Phantom®.
2. Using a 3mm Allen or Hex wrench, remove quantity (4) 4mm diameter Hex screws (item 2) from head of Grinder at the locations shown in Figure 2 below. Do not remove the grinder head. Save the screws to reassemble the grinder if it is removed from the Seam Phantom® in the future.



Item 1 – Wheel Guard

FIGURE 1 – Wheel Guard Removal

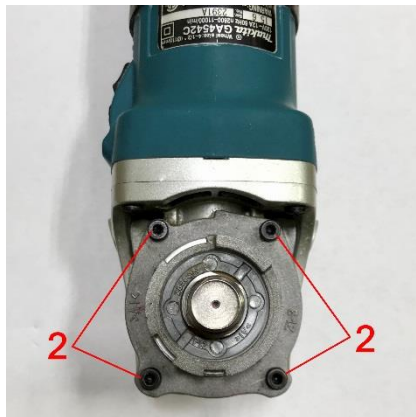

Item 2 – 4mm Screws

FIGURE 2 - Screw Removal

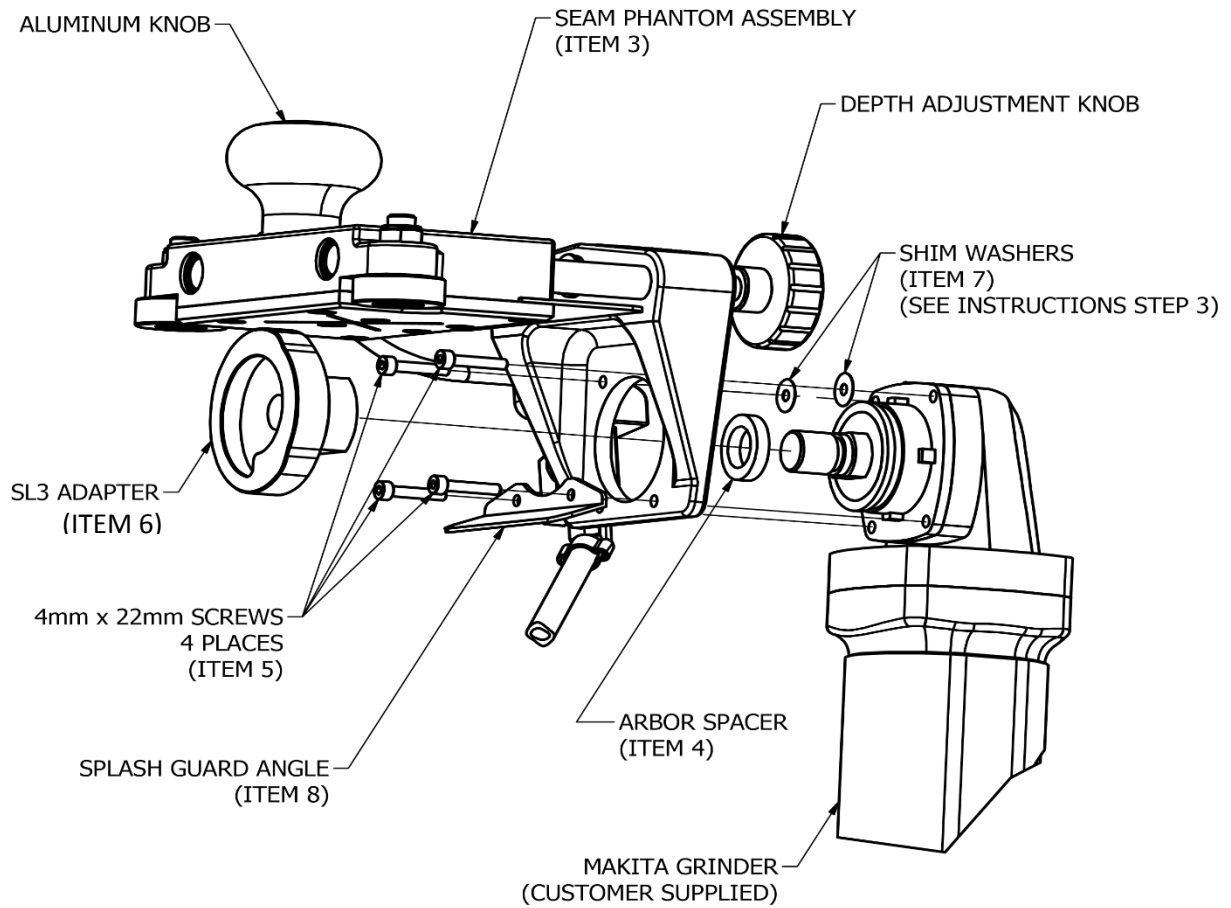

FIGURE 3 – Assembly Exploded View, Electric
(Spray Skirt not shown)

3. Position Seam Phantom® (item 3) and Splash Guard Angle (item 8), and attach to Grinder as shown in Figure 3 above using (4) 4mm X 22mm Hex Screws (item 5) supplied with Seam Phantom®. Insert shim washers (item 7) (optional) between grinder and Seam Phantom® to adjust the angle of the grinding pad as noted below. Tighten using a 3mm Allen (Hex) wrench.

NOTE: See section titled ***Adjusting the Seam Phantom®*** on Page 11 for detailed instructions on use of the shim washers to get the best result

4. If desired, fasten water supply hose to cord of Grinder using electrical tape or other suitable method.
5. Install arbor spacer (item 4) and SL3® Adapter (item 6) as shown in Figure 3 above. Tighten with crescent wrench.

6. Install Spray Skirt – see Figure 4, 5, 6 & 7 below
 - a) Clean grinder with denatured alcohol (or equivalent) prior to installing spray skirt
 - b) Mark the center of the skirt along the top edge to help center the spray skirt on the grinder
 - c) Install approximately 1/4 inch below the switch as shown
 - d) Peel backing from tape and install as shown in Figure 4, 5, 6 & 7 below. Tape is extremely sticky - care should be taken once the tape backing is removed
 - e) Skirt must be installed without gaps or wrinkles in the tape to minimize water penetration into the grinder
 - f) Fold back skirt and blow out grinder after each use



FIGURE 4 – Spray Skirt Installation



FIGURE 5 – Spray Skirt Installation



FIGURE 6 – Spray Skirt Installation



FIGURE 7 – Spray Skirt Installation Complete

7. NSI Solutions LLC has provided a GFCI adapter with the Seam Phantom® kit. Ensure the grinder or extension cord is plugged into this GFCI adapter or other GFCI protected circuit when in use (see Figure 7A).



FIGURE 7A - GFCI Adapter



Caution

Ensure GFCI remains connected to grinder at all times when in use or that the grinder is plugged into other GFCI protected circuit.

8. The unit is now ready for use.

Assembling the Seam Phantom® - Air Version

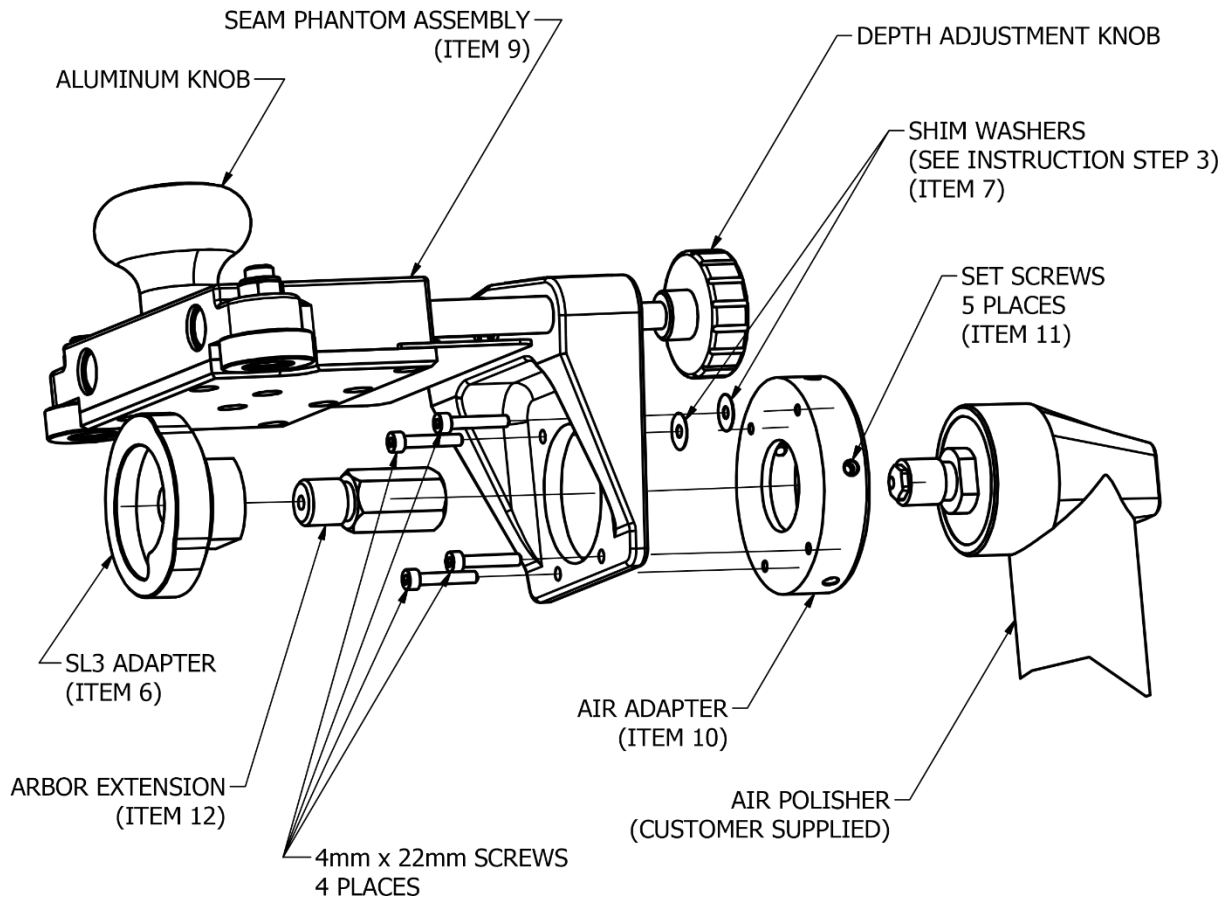

FIGURE 8 – Assembly Exploded View, Air

1. Attach the arbor extension (item 12) to the polisher as shown in Figure 8 above and tighten with $\frac{3}{4}$ " wrench.
2. Attach air adapter (item 10) to the polisher as shown in Figure 8 and Figure 9. Note that the air adapter has a recessed painted dot which should be oriented in the "up" position. Ensure polisher is firmly seated in the air adapter. Tighten the (5) set screws (item 11) using a $\frac{1}{8}$ Hex Wrench. The set screws have Loctite pre-applied. When using the Seam Phantom, check screws frequently for tightness.

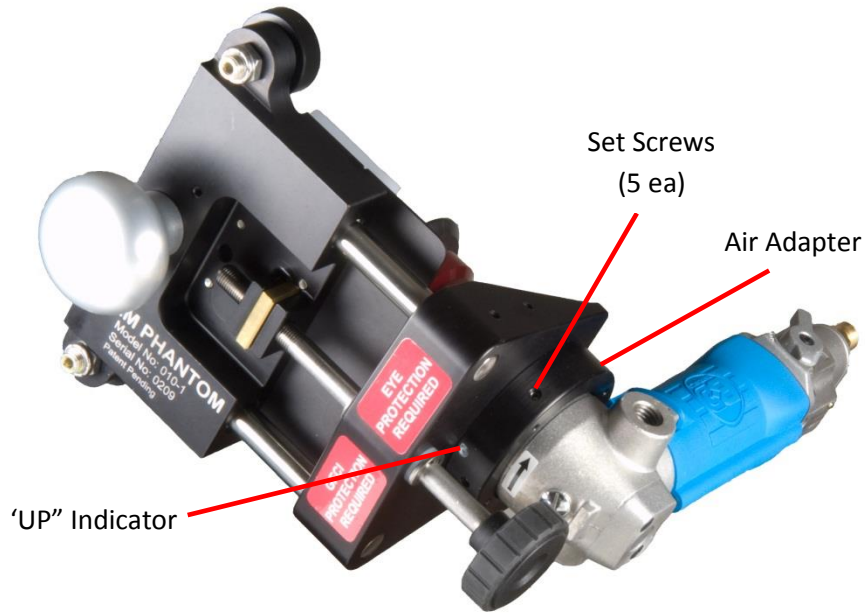

FIGURE 9 – Air Polisher Adapter

3. Attach the polisher, adapter and arbor extension to the rest of the Seam Phantom® (item 9) using (4) 4mm X 22mm Hex Screws (item 5) as shown in Figure 8. Insert shim washers (item 7) (optional) between adapter and Seam Phantom® to adjust the angle of the grinding pad as noted below.

NOTE: See section titled ***Adjusting the Seam Phantom®*** on Page11 for detailed instructions on use of the shim washers to get the best result.

4. Attach SL3® adapter (item 6) per Figure 8 and tighten with crescent wrench. The unit is now ready for use.

Adjusting the Seam Phantom®

To ensure the tightest possible seams, each Seam Phantom® is checked for squareness before it leaves the factory. Slight variations in grinders and polishers can affect the finished product so shim washers are provided to make final adjustments. A newly assembled Seam Phantom®/grinder should initially be checked with a good square and then tested and adjusted utilizing a sample seam ground on scrap stone as follows:

1. On a scrap piece of stone set up the Glide Guide and grind the first half of a finished seam per the instructions on page 13 thru 15 of the manual, steps 1 thru 6 and steps 8 thru 12. Skip step 7, "Back Grind". Dress the entire edge of the stone with the turbo pads to 150 grit. Make sure all the chips in the upper edge of the seam have been eliminated.
2. On a second scrap piece of stone create the mating half of the seam in the same way. Make sure all the chips in the upper edge of the seam have been eliminated.
3. Place the two halves of the finished seam together. Make sure the top of the sample is even and flat and observe the gap at the edge of the seam. The seam should be tight on the top edge. A slight gap on the bottom edge is acceptable and sometimes desirable. It is a matter of personal preference. Some fabricators prefer to make perpendicular tight seams from top to bottom. Other fabricators prefer a slight gap on the bottom to ensure the top is always tightest.
4. Add shim washers to the attachment screws as required to create the desired seam.
 - a) To correct a gap on the top edge, shim washers can be placed between the grinder and Seam phantom® (between the air adapter and Seam phantom® on air powered units) on the top two attachment screws. Utilize one or two washers on each screw as required. See Figure 3 (electric) or 8 (air) for correct washer location.

NOTE: *A single washer added to the top two attachment screws changes the angle of the turbo pad by approximately ¼ degree and will result in approximately .005" additional stone removed at the bottom of a 3cm sample (the approximate thickness of a human hair). This will correct an approximately .010" gap at the top of a finished seam when both halves are brought together.*
 - b) Shim washers may also be utilized on the lower two attachment screws to close an overly large gap on the lower edge of the seam.
5. After the washers have been added repeat the process to ensure the desired seams are being produced.
6. The Seam phantom® is now set to produce consistent tight seams. Occasionally this process may need to be repeated as the plastic base plate that slides on the Glide Guide wears.

USE INSTRUCTIONS

Before Using the Seam Phantom®

Before using the assembled Seam Phantom® be sure to complete the following preparations.



Supply the Specified Voltage (electric version)

Supply the voltage specified on the nameplate of the grinder. Otherwise damage could result to the machine, or increase the risk of personal injury.



Install a Ground Fault Circuit Interrupter (GFCI) (electric version)

To prevent electrical shocks, be sure that the power circuit being used is protected by a GFCI device or be sure to install the supplied ground fault circuit interrupter (GFCI) between the main power supply and the cord of the machine.



Keep Water Out of the Grinder (electric version)

Do not let water into the motor of the electric grinder. Water inside the machine will weaken the electrical insulation of the motor and may result in electric shock. Ensure the spray skirt (see Figure 4 to 7) and splash guard angle (see Figure 3) are installed at all times during use.



Organize the Work Area for Safe Operation

Before beginning operations, make sure that the work area conditions are well organized for safe operation of the Seam Phantom®



Use Proper Safety Gear

To prevent damage to eyes from flying debris, wear protective glasses or face shield. Be sure to wear waterproof safety boots, appropriate hearing protection and dust protection as required.

How to Operate

Work Piece Setup

1. Set your work piece on the work bench and secure it using appropriate clamps. Take care to leave enough overhang for the grinding pad to get all the way to the end of the slab, and for the guide rail clamps to clear the work bench.

NOTE: To allow for removing material, the seam should be “overcut” during the sawing process by as much as the largest chips in the upper edge (typically around 1 mm or 0.04”).

Guide Setup

2. Using your template or other method, determine final location for the seam. Mark with tape cut to the template or other preferred method.
3. Use two gauge blocks to line up the Glide Guide straight edge parallel to the seam. See Figure 10 below.
4. Your Glide Guide (guide rail) should extend a minimum of 3” (7.5 cm) past both sides of the stone. Make sure that you select the correct size Glide Guide for your work piece. A 48” Glide Guide is supplied with each kit and will work for most standard seams. 72” and 92” Glide Guides are also available.
5. Clamp Glide Guide straight edge using appropriate clamps on the back edge (the edge opposite the seam) at each end.
6. Remove gauge blocks after the glide guide is clamped in place and prior to grinding any stone.

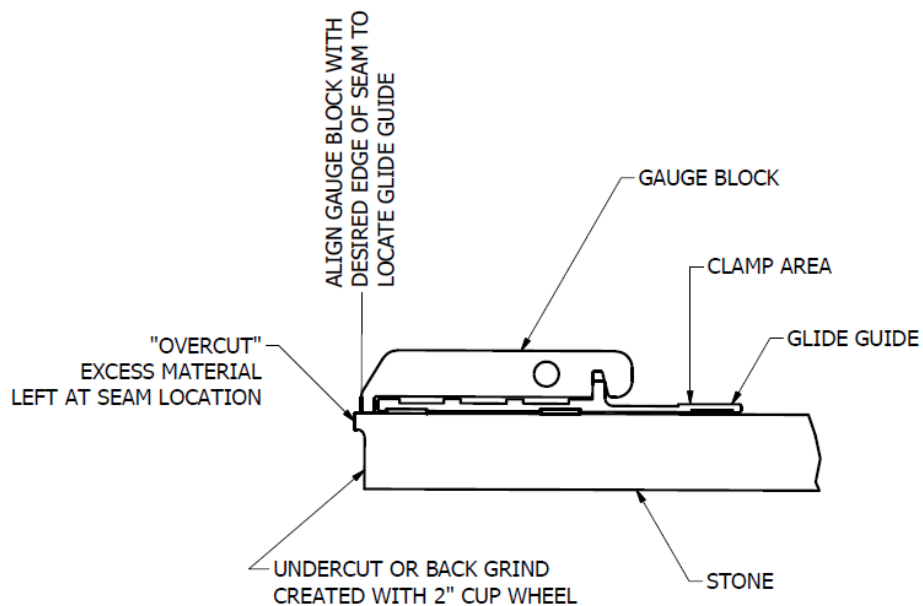

FIGURE 10 – Gauge Block Use

Back Grind or “Undercut”

7. The back grinding is done using the 2” cup wheel. Ensure adequate water flow is provided by adjusting the valve. Lock the 2” cup wheel into the snail lock adapter and back grind slightly more material than you'll be dressing off with the turbo pads. Example – If 1 mm is going to be removed with the turbo pads, approximately 1.5 mm should be removed with the 2” cup wheel. One full turn of the Depth Adjustment Knob (see figure 11 below) equals 1 mm. This material should be removed in ½ turn (0.5 mm) increments until 1.5 mm is removed.
Be sure to stop the back grind short of the front profiled or polished edge to avoid a large gap in the front edge. This back grind will allow the turbo pads to dress the upper portion of the seam more efficiently and will also provide a rough surface on the lower portion for the seaming adhesive to adhere to.



Caution

The SL3® Cup Wheel is made to be used with water. With the electric model, adjust water flow to ensure the water is hitting the “backstop” of the SL3® 2” cup wheel and splashes onto the grinding area. With the air model, the water is fed through the center water feed of the polisher. **DO NOT OVERHEAT** the Cup Wheel by operating it dry. Max speed for the 2” Cup Wheel is 10,000 RPM.

Dressing the Seam (Suggested Process)

8. Start with either the SL3® 60 or 150 Grit Turbo Pad. Lock the desired turbo pad into the snail lock adapter.

NOTE: Which grit to start with will depend on the size of chips in the edge, and how much material is to be removed. Use the 60 grit to remove large chips and excess material. Use the 150 grit for smaller chips and fragile material.

9. Turn the adjustment knob counter clockwise to back the turbo pad off the stone so it's not touching the stone.
10. Turn on the power and water. Adjust the water valve to ensure an adequate water supply.

NOTE: The electric version has the water valve mounted on the Seam Phantom® itself. Use the valve to control the volume of water being used and to avoid excessive water spraying onto the grinder. The grinder will last longer if it is kept dry.



Caution

The SL3® Turbo Pads are made to be used with water. Adjust the water valve to ensure an adequate water supply. **DO NOT OVERHEAT** the Turbo Pads by operating them dry. Max speed for the SL3® Turbo Pads is 4,000 RPM.

11. Turn the adjustment knob clockwise until the turbo pad just touches the stone (this is your zero point) and begin grinding the seam back and forth keeping the wheels in contact with the vertical edge of the Glide Guide as shown in Figure 11 below.
12. Starting from the zero point, turn the adjustment knob in small increments to gradually cut deeper. Keep working the Seam Phantom® back and forth grinding away the stone until the cut is almost to the final seam location (stop short so you can finish with the 300 grit turbo).

NOTE: *For best results, only apply pressure to the tool using aluminum knob above the flat surface of the straight edge. Do not apply pressure via the polisher or by pushing on the adjustment knob.*

13. Repeat process using the 300 grit pad. (This is optional and depends on the type of material being dressed. You might find that your results from the 150 grit pad are sufficient.)
14. Continue until finished edge is at the desired seam location with no edge chipping. Continuing until pad is no longer grinding the stone along the entire edge will ensure a straight and chip free edge.
15. To check the straightness of the seam, with the power and water off, the Seam Phantom® can be lightly rolled from left to right across the Glide Guide to see if the turbo pad drags or turns on a high spot. If the turbo pad does not drag or turn, the seam is finished. If there is an area where the turbo pad drags or turns on a high spot, this area needs to be corrected. Without moving the Depth Adjustment Knob, turn on the power and water and continue working the seam until the high spot is removed.

Quick Tip: This is a suggested process that will work on most natural and engineered stones when starting with a good bridge saw cut. After removing 1.5 mm of material with the 2" cup wheel as described above, switch to the 150 grit turbo. With the 150 grit turbo, remove 0.75 mm (¾ turn) taken in ¼ turn increments. Be sure that the 150 grit turbo is no longer removing material before switching to the 300 grit turbo. With the 300 grit turbo, remove 0.25 mm (¼ turn) taken in 1/8 turn increments. Be sure that the 300 grit turbo is no longer removing material before checking the seam for straightness.

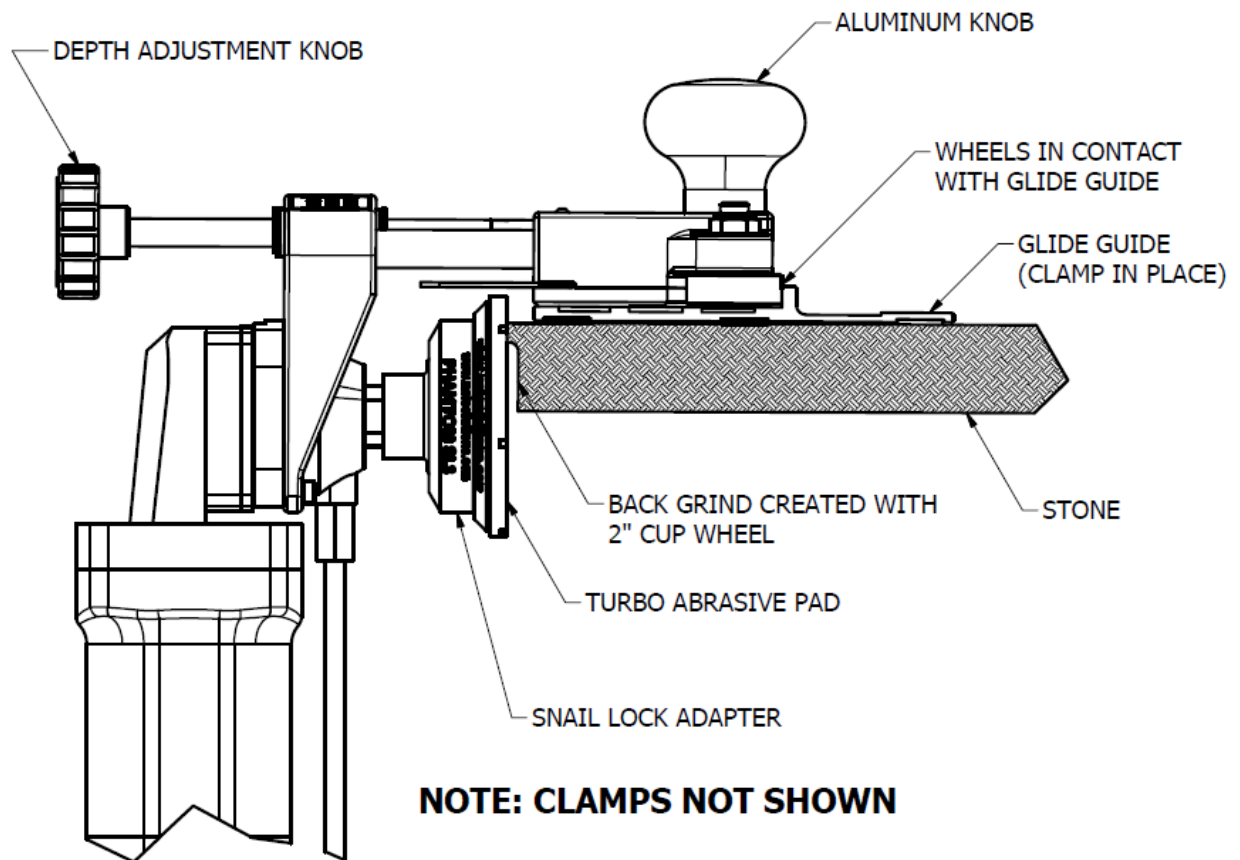

FIGURE 11 – Dressing the Seam

After Use

Clean and dry the electric grinder and lubricate the air polisher as noted in the Cleaning and Maintenance section.

CLEANING AND MAINTENANCE



Caution

Always be sure that the tool is switched off and unplugged before attempting to perform inspection or maintenance.



Caution

The grinder air vents need to be kept clean. Regularly clean the grinder air vents or clean the vents whenever they start to become obstructed.



Caution

To maintain product SAFETY and RELIABILITY, repairs to the grinder or air polisher should be done by an Authorized or Factory Service Center.

The following procedure will extend the longevity of your Seam Phantom®

1. **Electric version** - Fold back the spray skirt and blow out the grinder vents after each use using a dry air supply to remove any dust or moisture. This will extend the life of the electric motor.
2. **Air Version** - Perform regular lubrication and other maintenance of the air polisher as recommended by the manufacturer
3. **Cleaning Guide Rods and Bushings** - After heavy use, the in and out adjustment of the Seam Phantom® may become “stiff”. Performing the following steps should correct this. See Figure 12 below.
 - a. Disconnect the water feed hose (electric version only) at the valve end with the quick disconnect tube fitting, by pushing the ring towards the hose fitting.
 - b. Turn the adjustment knob counter clockwise until the adjustment screw disengages from the square nut and the two halves of the Seam Phantom® can be separated. Do not lose the square nut.
 - c. Use a paper towel or other soft material and push through the bushing holes, sliding back and forth until all grit is removed.
 - d. Using a soft towel or material, wipe the stainless shaft guide rods clean.
 - e. Clean screw threads on the adjustment screw with water and a brush.
 - f. Reassemble the two halves of the Seam Phantom® and re-connect the water hose by pushing it in until it snaps in place.

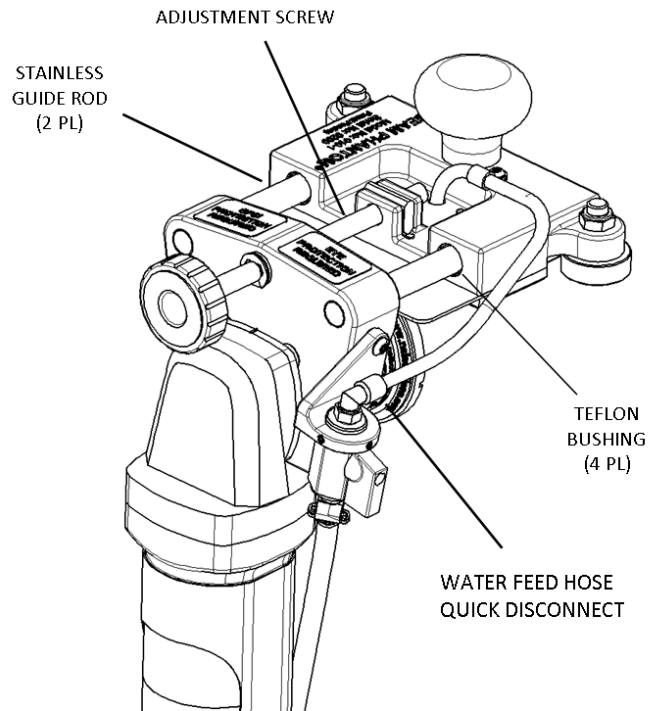

FIGURE 12 – Cleaning (Electric version shown)

CONTACT NSI SOLUTIONS

If you need help locating replacement items or just have questions, feel free to contact us.

You can reach us at:

Web: nsisolutions.com

Email: info@nsisolutions.com

Phone: 425-297-3162

Snail Mail: NSI Solutions LLC
13020 Mukilteo Speedway, Suite A
Lynnwood, WA 98087

Usage Tips: For usage help and/or tips visit nsisolutions.com or watch the videos on our YouTube channel [NSITools](#).